

DASH NO.	M CODE	MADE FROM
----------	--------	-----------

GSD

1944-1-9

REVISIONS	
ISSUE	CHANGES
5	CN 32735 A REDRAWN WJM 12/07/90
6	CN 35886 E KH 11/16/94
7	CN 36666 C KH 11/14/95

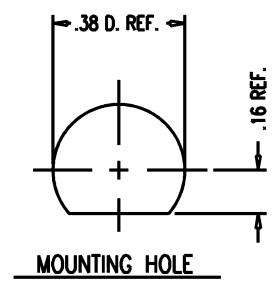
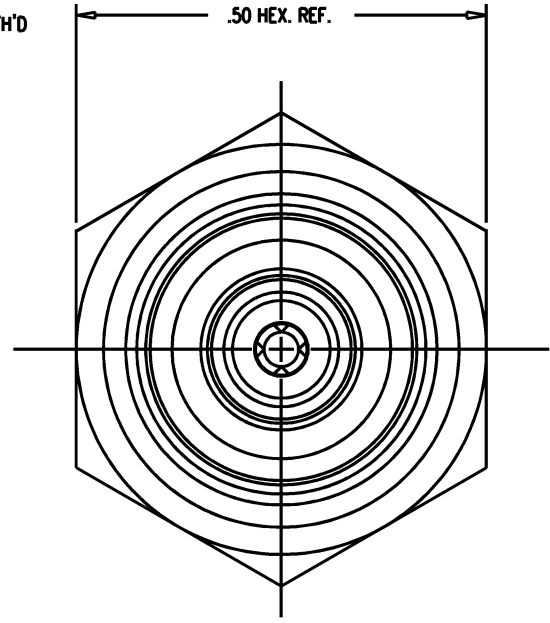
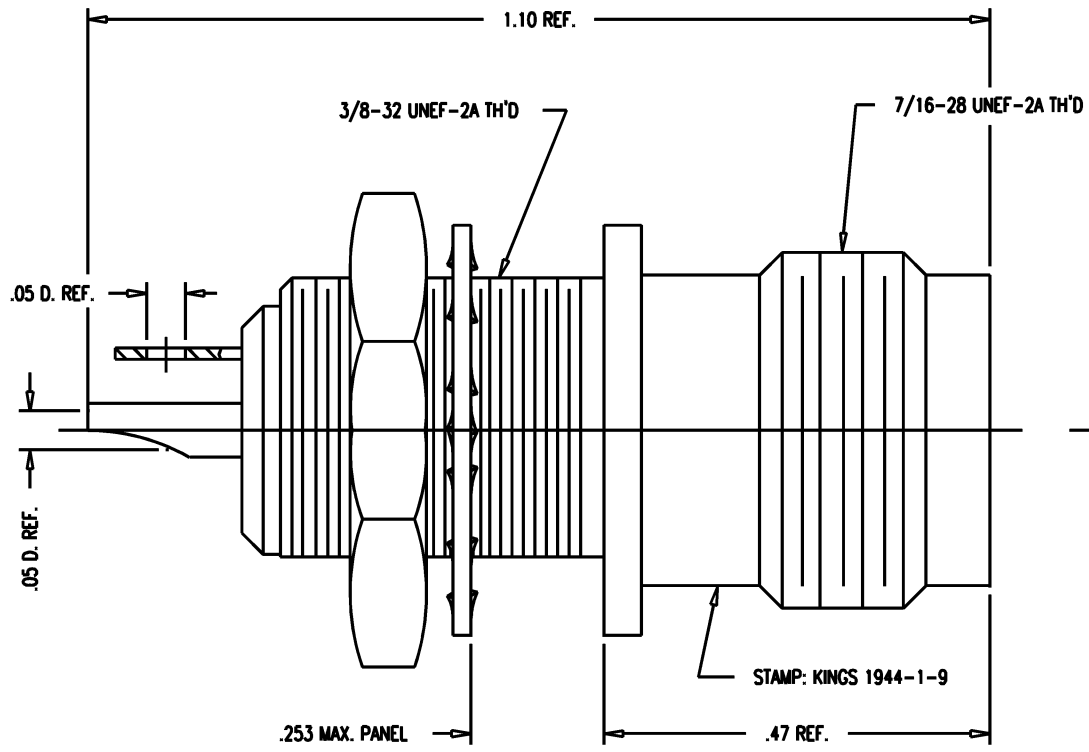

NOTES:

1. INTERFACE PER MIL-STD-348, FIG. 202-2.
2. MATERIALS:
INSULATORS: TEFLON, ASTM-D-4894
CENTER CONTACT: BER. COPPER, ASTM-B-196
LOCKWASHER: PHOSPHOR BRONZE, ASTM-B-103
ALL OTHER METAL PARTS: BRASS, ASTM-B16
3. FINISHES:
CENTER CONTACT: HARD GOLD PLATE, PER MIL-G-45204
INTER. CONTACT: NICKEL PLATE, QQ-N-290
ALL OTHER METAL PARTS: KINGS TARNISH RESISTANT NICKEL FINISH (TR-5)
4. ELECTRICAL CHARACTERISTICS:
WORKING VOLTAGE: 400 VRMS
FREQUENCY RANGE: DC TO 500 MHZ.

SCALE	6:1
APPROX SURFACE AREA	
USED ON	
REF:	
RECEPTACLE, BULKHEAD, TRT	
DRAWN WJM	10/07/90
DESIGN CT	03/07/90
APPR. JT	03/07/90

KINGS
ELECTRONICS CO., INC.
TUCKAHOE, NEW YORK 10707

GSD

1944-1-9